

Building a high voltage (5KV), variable plate capacitor (17 to 220pF)

Rotor Pos.1

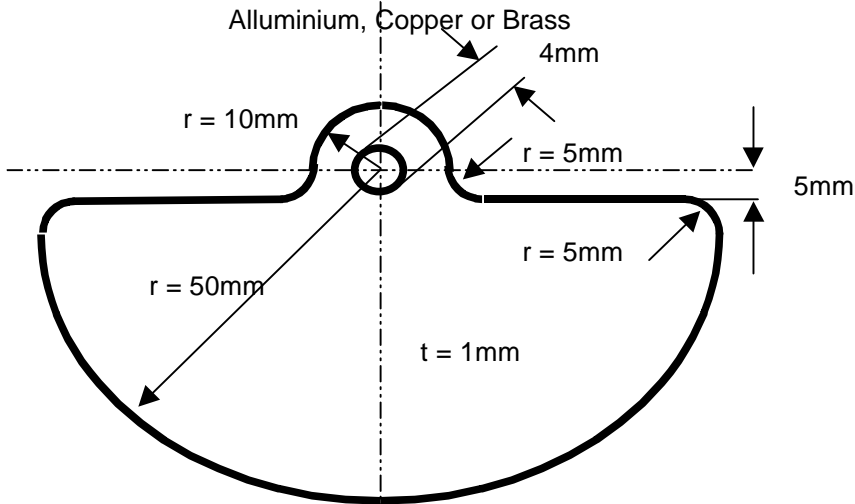

Stator Pos. 2

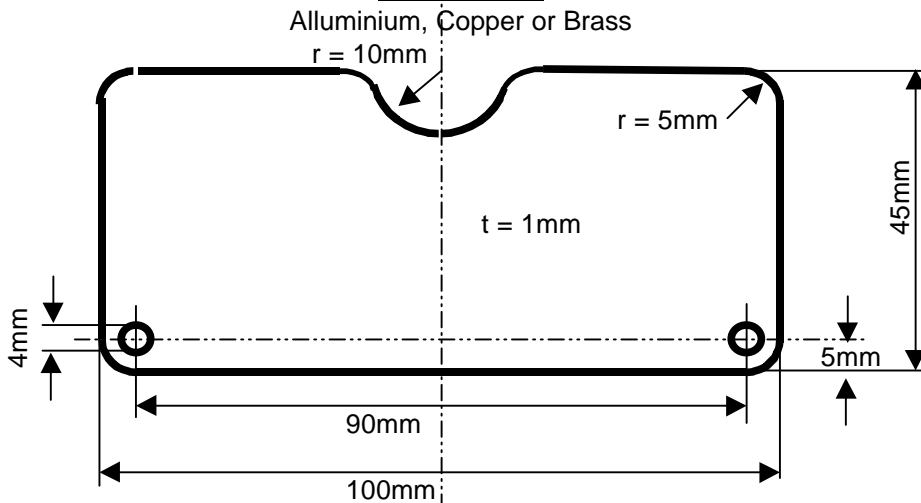

Distance rolls with a 4,2mm hole

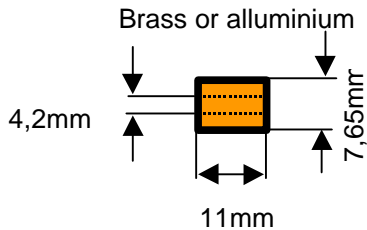

Contactt plate Pos. 4

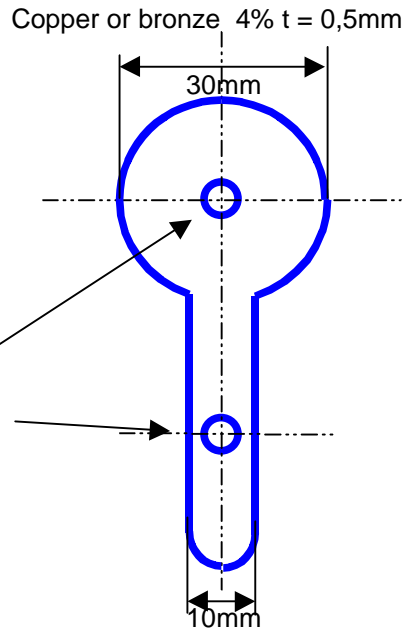

Rotary contactt Pos. 5

Bronze 8% $t = 0,5\text{mm}$

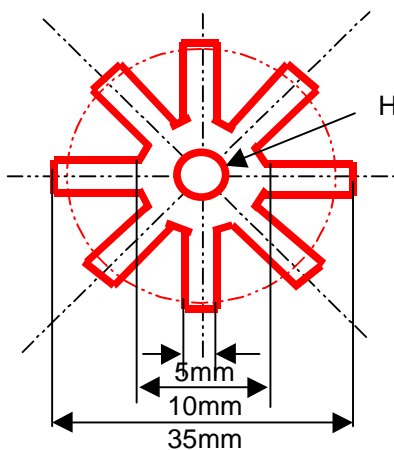

Dipending on the amount of needed stator and rotor plates, you have to dimension the screwrod to fit it.

Front and rear isolation plates made of 4mm epoxy

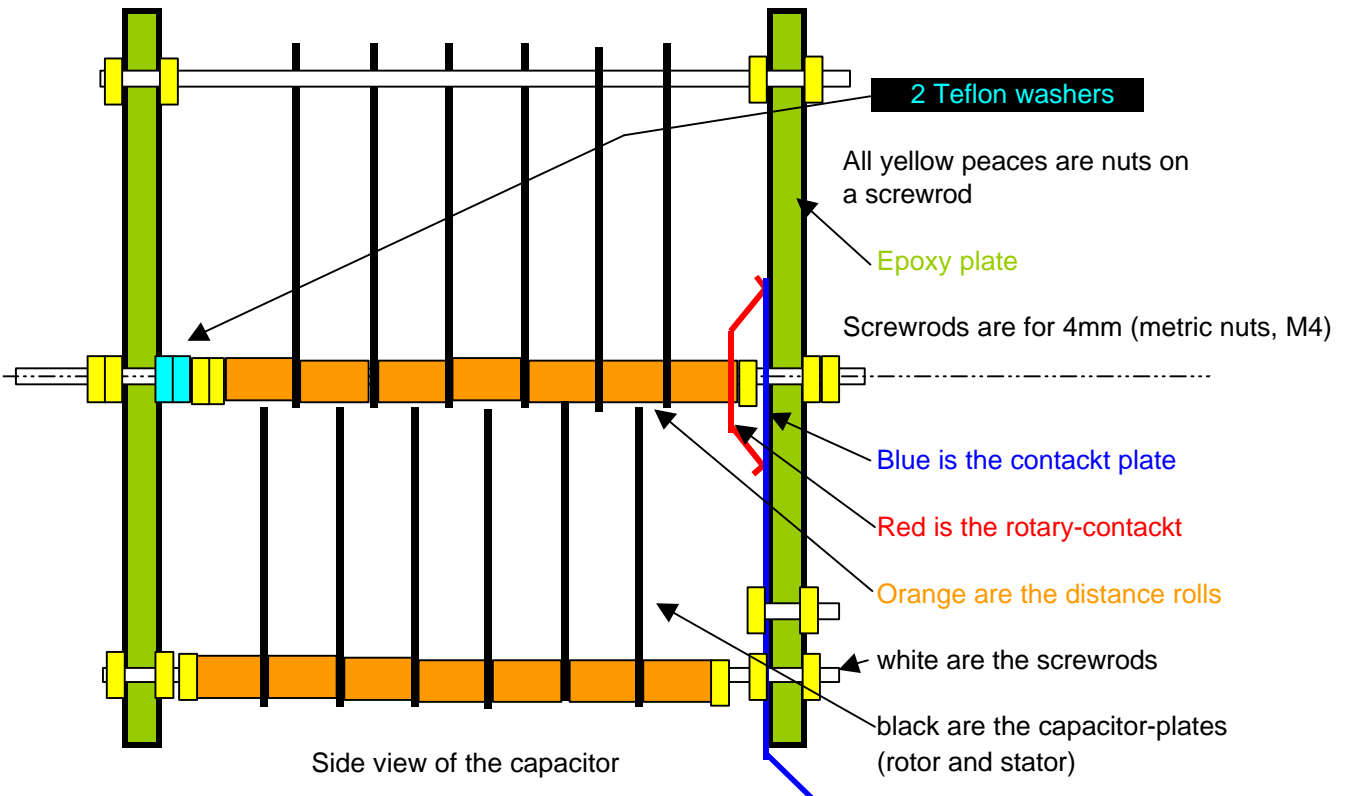
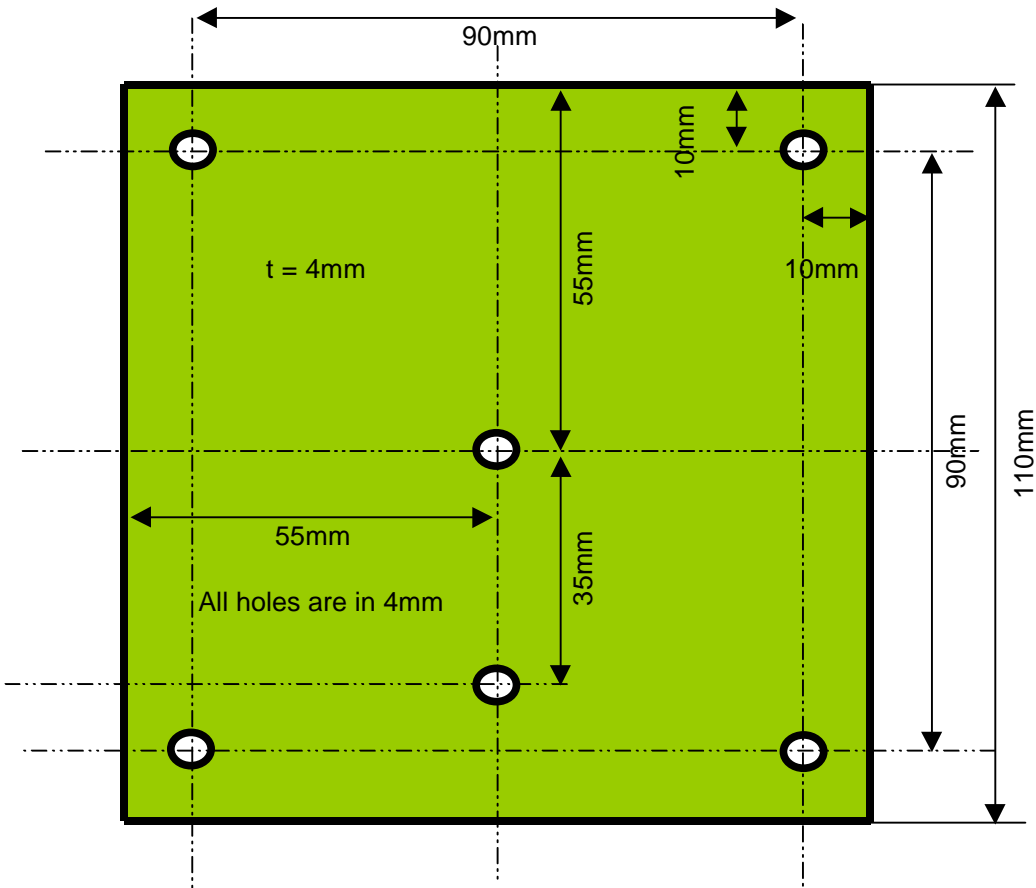

Front-view of the front and rear epoxy-sections with the components in place

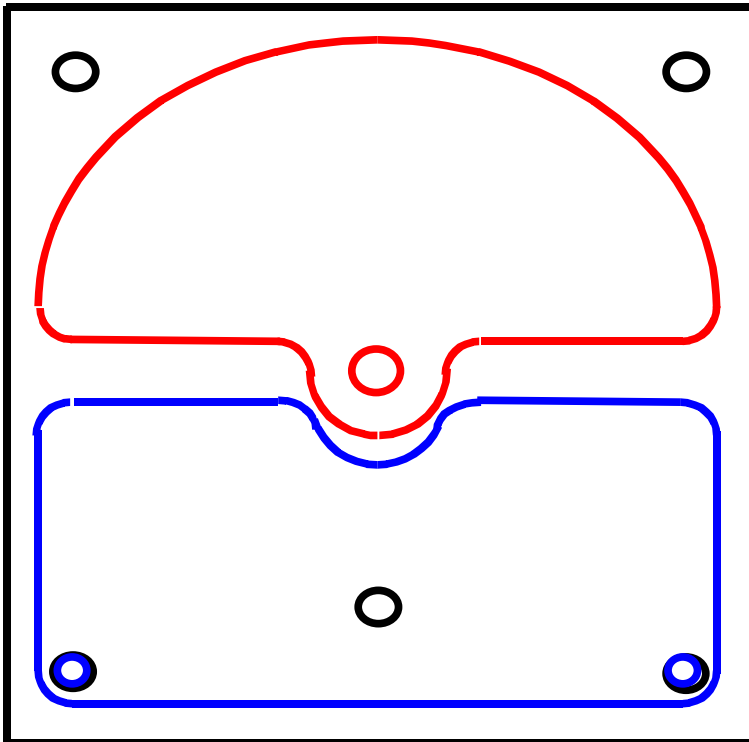

To get a capacitance of about 220pf you need 10 stator and 9 rotor plates that means about 22pf per pair of plates.

Plates at minimum capacitance

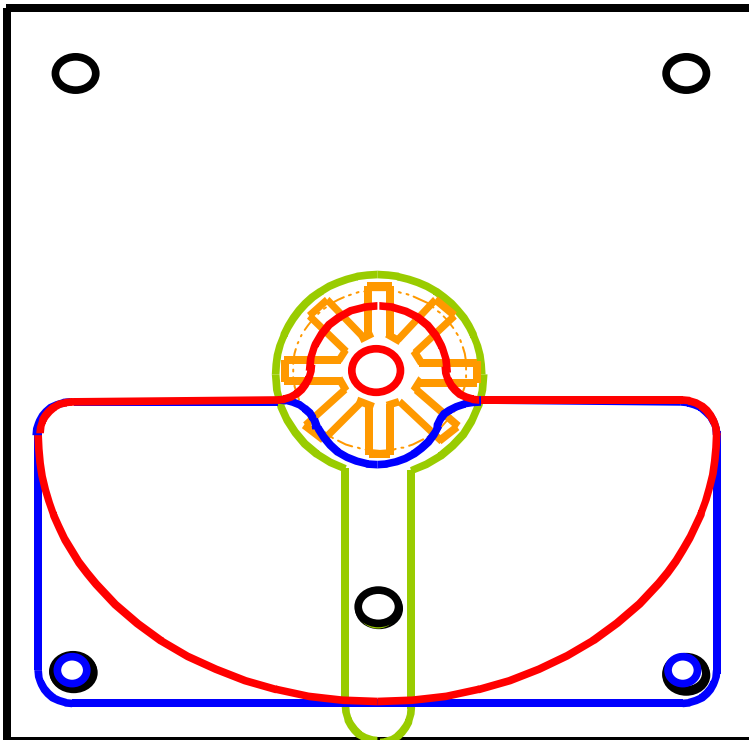

Here is a view of the components from the far back to the front.....epoxy-plate (black).....contact-plate (green).....rotary-contact (orange)....stator-plate (blue)....rotor-plate (red).. And so on, continuing with the plates and their distance-rolls.

Plates at maximum capacitance

Here a few images in order to show you that the project is possible, the isolation-plates here are made of plexiglas to have a better look on it.

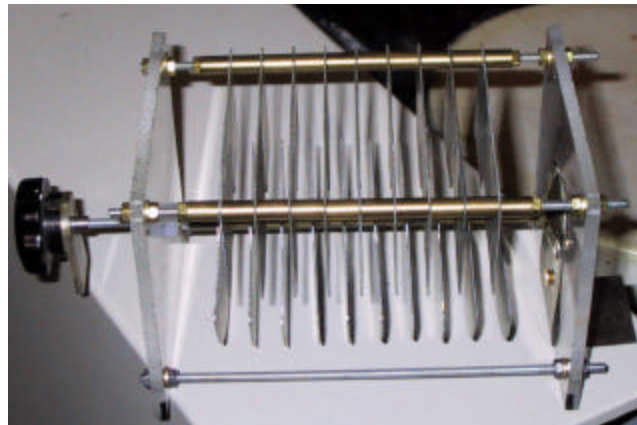
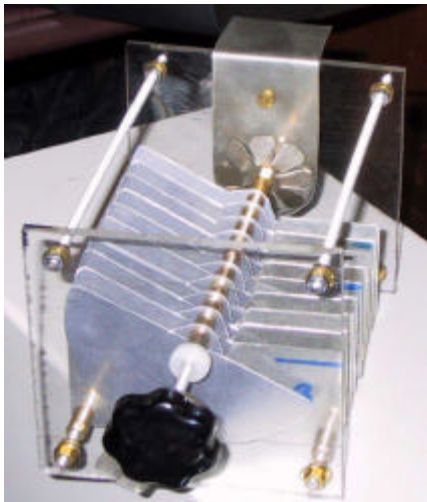
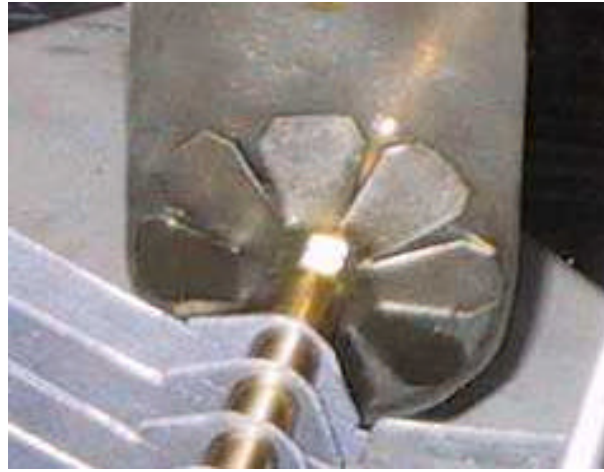
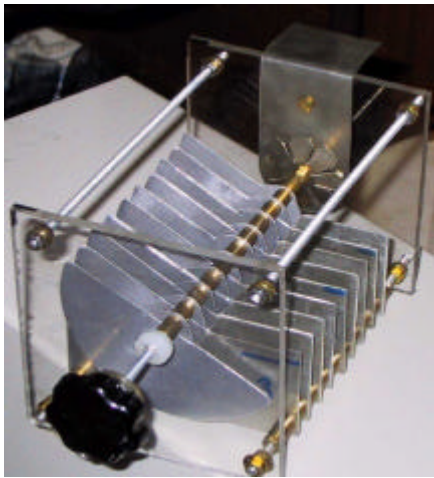
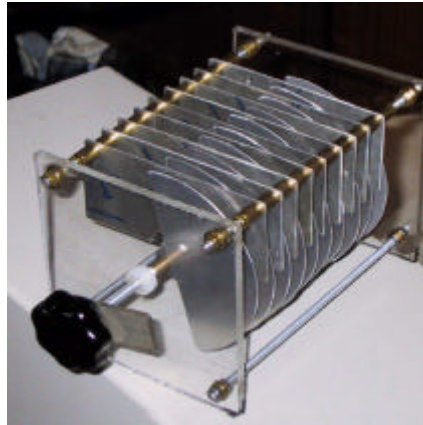
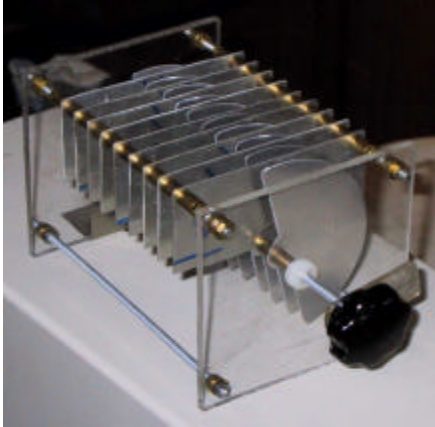

As you see it is possible, rotaiting is a bit harder then a commercial one but you need the pressure between the isolation-plates to get a good contact from the rotary-section to the contact-plate. I also used this homebrew variable capacitors for magnetic loops.

If you like this description, I would apprischiate a good note.

Please rate my sight at the DX-Zone

73 and good luck homebrewing this capacitor. DL 5 DBM, Anwar.